

WineZone 2400a Ductless Split Specifications

Condenser:

<u>Voltage</u>	<u>Ampacity</u>	<u>Max. Fuse</u>	<u>Min. Wire Size</u>	<u>RLA/LRA</u>	<u>dB</u>
115-60-1	9.5	15	12-2 w/Gr	6.9/39	50

- 1/4" x 3/8" line set up to 70 equivalent feet. See the installation instructions for line set sizing up to 200 equivalent feet maximum.
- Unit is not precharged and must be evacuated
- For use with R-134a refrigerant.
- Indoor condensers must be installed in a room with a minimum of 1240 cubic feet of free space

➤ Dimensions:

Indoor Unit: 25" x 20 1/2" x 14 1/2"	89 lbs.
Outdoor Unit: 27" x 20" x 20"	114 lbs.

Wall Mounted Evaporator:

<u>Voltage</u>	<u>Motor Output</u>	<u>Filter</u>	<u>dB</u>
115-60-1	12 Watts	Washable	40

- Receives load voltage from condenser
- Drain line is 5/8" barbed
- Dimensions: 29 3/8" W x 10 5/8" H x 8 1/8" D 17 lbs.

Thermostat:

- PRO 1 or Peco 12532 if ordered with humidifier
- 18-gauge 5-wire to the condenser

Approximate Shipping Weight: 210-250 lbs

Crate Size: 31" x 37" x 41" T

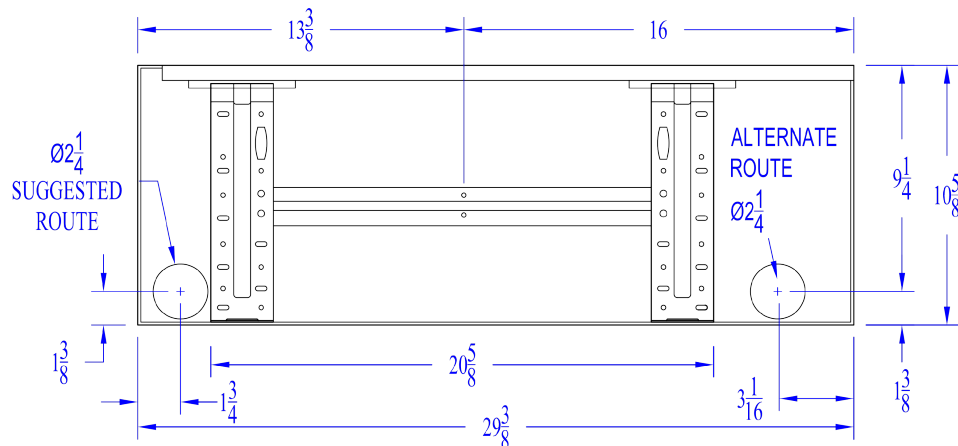

Evaporator Template
Possible Routes for Refrigerant Lines, Drain, and Electric
(Only One Hole Needed)

The holes shown are the best locations to route the refrigerant lines, condensate drain, and electric. For installations where the line set will be accessible on the backside of the wall, use the alternate route. When the line set will be run inside the wall before the drywall is installed, use the suggested route. This will leave the flare connections exposed so they can be connected after the walls are finished.